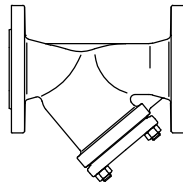


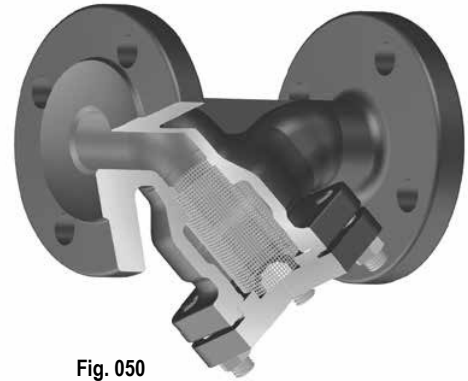
**ARI-Strainer - Screen and supporting basket made of stainless steel**
**ARI-Strainer -**
**Y-pattern with flanges**

- TRB 801 Annex II No. 45 (except EN-JL1040)
- EN ISO 15848-1 / TA - Luft  
TUV-Test-No. TA 09 2016 C04

Grey cast iron  
SG iron  
Cast steel

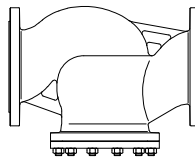

**Fig. 050**

Page 2


**Fig. 050**
**ARI-Strainer -**
**Straight through with flanges**

- TRB 801 Annex II No. 45
- EN ISO 15848-1 / TA - Luft  
TUV-Test-No. TA 09 2016 C04

SG iron  
Cast steel

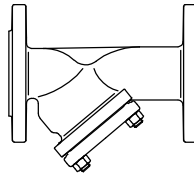

**Fig. 050**

Page 3

**ARI-Strainer -**
**Y-pattern with flanges**

- TRB 801 Annex II No. 45
- EN ISO 15848-1 / TA - Luft  
TUV-Test-No. TA 09 2016 C04

Stainless steel

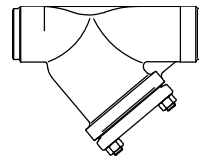

**Fig. 059**

Page 4

**ARI-Strainer -**
**Y-pattern with butt weld ends**

- TRB 801 Annex II No. 45
- EN ISO 15848-1 / TA - Luft  
TUV-Test-No. TA 09 2016 C04

Cast steel


**Fig. 080**

Page 6

**Features:**

- Screen and supporting basket made of stainless steel
- Screen from DN50 with reinforced ring
- Screen from DN150 with supporting basket
- Precise guidance of screen in cover and body

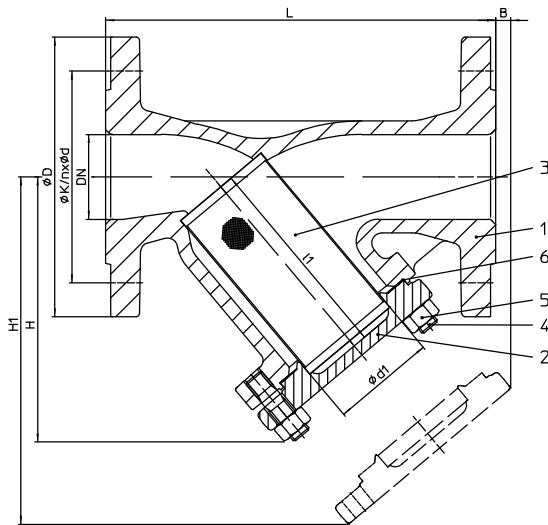
**Strainer - Y-pattern with flanges (Grey cast iron, SG iron, Cast steel)**


Figure	Nominal pressure	Material	Nominal diameter
10.050	PN6	EN-JL1040	DN15-200
12.050	PN16	EN-JL1040	DN15-300
22.050	PN16	EN-JS1049	DN15-300
23.050	PN25	EN-JS1049	DN15-150
34.050	PN25	1.0619+N	DN15-200
35.050	PN40	1.0619+N	DN15-200

A supporting basket is necessary, with higher differential pressures, dependent on clogging-up (DN >125 standard)

Test: • EN ISO 15848-1 / TA - Luft TÜV-Test-No. TA 09 2016 C04

Parts					
Pos.	Sp.p.	Description	Fig. 10./12.050	Fig. 22./23.050	Fig. 34./35.050
1		Body	EN-JL1040, EN-GJL-250	EN-JS1049, EN-GJS-400-18U-LT	GP240GH+N, 1.0619+N
2		Cover	DN ≤150: EN-JL1040, EN-GJL-250 DN >150: P265 GH, 1.0425	DN ≤80: EN-JS1049, EN-GJS-400-18U-LT DN >80: P265 GH, 1.0425	DN ≤80: P250 GH, 1.0460 DN >80: P265 GH, 1.0425
3	x	Screen	X5CrNi18-10, 1.4301		
3.1		Supporting basket	DN >125: X5CrNi18-10, 1.4301		
4		Stud	25CrMo4, 1.7218		
5		Hexagon nut	C35E, 1.1181		
6	x	Gasket	Pure graphite (CrNi laminated with graphite)		
L Spare parts					

DN	15	20	25	32	40	50	65	80	100	125	150	200	250	300
----	----	----	----	----	----	----	----	----	-----	-----	-----	-----	-----	-----

Face-to-face dimension FTF series 1 according to DIN EN 558 Standard-flange dimensions refer to page 7

L	(mm)	130	150	160	180	200	230	290	310	350	400	480	600	730	850
---	------	-----	-----	-----	-----	-----	-----	-----	-----	-----	-----	-----	-----	-----	-----

Dimensions																
H	(mm)	90	100	115	125	150	160	180	215	235	275	305	390	540	680	
H1	(mm)	135	150	180	205	235	250	285	330	365	425	480	610	915	1110	
B	(mm)	10	10	25	35	45	45	25	40	55	65	50	80	230	350	
l1	(mm)	56	68	82	98	114	119	134	149	169	199	224	284	434	555	
Ød1	(mm)	23	28	36	42	50	61,5	78,5	89,5	109,5	137,5	160	210	258	308	
Standard screen	Mesh width	(mm)	1	1	1	1	1	1,25	1,25	1,6	1,6	1,6	1,6	1,6	1,6	
	Kvs-value <sup>1)</sup>	(m³/h)	6,9	10,8	17,8	26,1	36,7	61	98,6	146	234	376	398	652	1225	1873
	Zeta-value	--	1,7	2,2	2	2,5	3	2,7	2,9	3,1	2,9	2,8	5,1	6	4,2	3,7
Fine screen	Mesh width	(mm)	0,25	0,25	0,25	0,25	0,25	0,25	0,25	0,25	0,25	0,25	0,25	0,25	0,25	
	Kvs-value <sup>1)</sup>	(m³/h)	6,2	10,1	16,8	24,3	32,9	49,5	80,3	115	189	303	378	590	1231	1883
	Zeta-value	--	2,1	2,5	2,2	2,8	3,8	4,1	4,4	4,9	4,5	4,2	5,6	7,3	4,1	3,6
Ratio of the free screen surface area to the area of the nominal diametSp.p.			10	8,4	8,3	7,1	6,4	5,2	4,4	3,7	2,8	2,7	2,4	2,3	2,7	2,9
Zeta-value ... range of tolerance for Kvs-values acc. to VDI/VDI 2173											<sup>1)</sup> Kvs-values based upon clean screen!					

Weights															
10.050	(kg)	2,5	3	4,5	5,5	7	9	13	19	26	38	54	110	--	--
12.050	(kg)	3	4	5	7	9	12	16	21	30	43	61	121	154	335
22.050	(kg)	3,5	4	5,5	7	9	12	16	21	28	41	58	115	154	335
23.050	(kg)	3,5	4	5,5	7	9	12	16	21	32	47	64	--	--	--
34./35.050	(kg)	4	5	6	8	10	13	19	24,5	35	51	71	144	--	--

Information / restriction of technical rules need to be observed!

Operating and installation instructions can be downloaded at [www.ari-armaturen.com](http://www.ari-armaturen.com).

ARI-Valves of EN-JL1040 are not allowed to be operated in systems acc. to TRD 110.

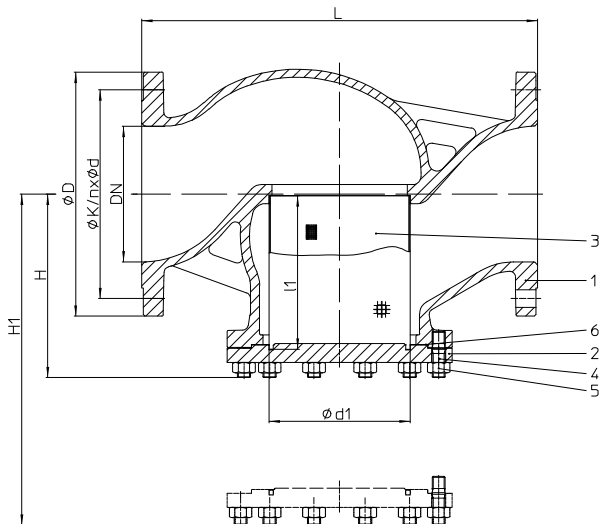
A production permission acc. to TRB 801 No. 45 is available (acc. to TRB 801 No. 45 EN-JL1040 is not allowed.)

The engineer, designing a system or a plant, is responsible for the selection of the correct valve.

Resistance and fitness must be verified (contact manufacturer for information, refer to Product overview and Resistance list).

**Strainer - Straight through with flanges (SG iron, Cast steel)**

Figure	Nominal pressure	Material	Nominal diameter
22.050	PN16	EN-JS1049	DN350
34.050	PN25	1.0619+N	DN250-500
35.050	PN40	1.0619+N	DN250-500



Parts				
Pos.	Sp.p.	Description	Fig. 22./23.050	Fig. 34./35.050
1		Body	EN-JS1049, EN-GJS-400-18U-LT	GP240GH+N, 1.0619+N
2		Cover	P265 GH, 1.0425	P265 GH, 1.0425
3	x	Screen	X5CrNi18-10, 1.4301	
3.1		Supporting basket	X5CrNi18-10, 1.4301	
4		Stud	25CrMo4, 1.7218	
5		Hexagon nut	C35E, 1.1181	
6	x	Gasket	Pure graphite (CrNi laminated with graphite)	
	L	Spare parts		

DN	250	300	350	400	500
----	-----	-----	-----	-----	-----

**Face-to-face dimension FTF series 1 according to DIN EN 558**

L	(mm)	730	850	980	1100	1350
---	------	-----	-----	-----	------	------

**Abmessungen**

	(mm)	340	375	430	440	545	
H	(mm)	650	690	800	830	1015	
H1	(mm)	283	317	367	377	462	
l1	(mm)	260	314	364	414	514	
Ød1	(mm)						
Standard screen	Mesh width	(mm)	1,6	1,6	3	3	
	Kvs-value <sup>1)</sup>	(m <sup>3</sup> /h)	910	1500	1730	2250	3407
	Zeta-value	--	7,5	5,7	8	8,1	8,6
Fine screen	Mesh width	(mm)	0,25	0,25	0,8	0,8	0,8
	Kvs-value <sup>1)</sup>	(m <sup>3</sup> /h)	865	1426	1650	2140	3250
	Zeta-value	--	8,3	6,36	8,8	8,9	9,5
Ratio of the free screen surface area to the area of the nominal diametSp.p.		2,7	1,7	2,0	1,7	1,7	

Zeta-value ... range of tolerance for Kvs-values acc. to VDI/VDE 2173 <sup>1)</sup> Kvs-values based upon clean screen!

**Weights**

22.050	(kg)	--	--	322	--	--
34./35.050	(kg)	235	297	462	675	986

Information / restriction of technical rules need to be observed!

Operating and installation instructions can be downloaded at [www.ari-armaturen.com](http://www.ari-armaturen.com).

A production permission acc. to TRB 801 No. 45 is available.

The engineer, designing a system or a plant, is responsible for the selection of the correct valve.

Resistance and fitness must be verified (contact manufacturer for information, refer to Product overview and Resistance list).

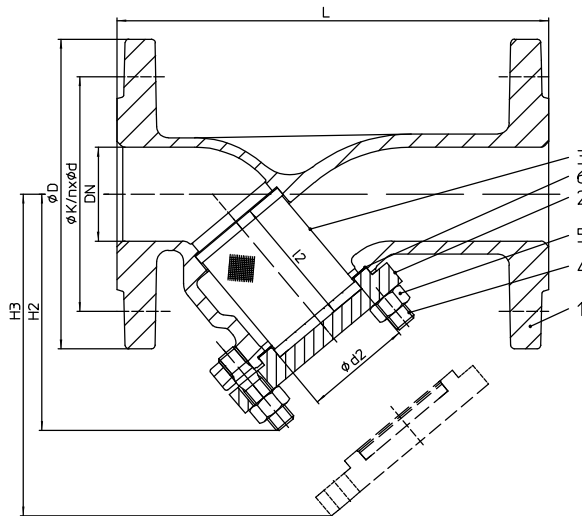
**Strainer - Y-pattern with flanges (Stainless steel)**


Figure	Nominal pressure	Material	Nominal diameter
52.059	PN16	1.4408	DN15-200
54.059	PN25	1.4408	DN15-200
55.059	PN40	1.4408	DN15-200

A supporting basket is necessary, with higher differential pressures, dependent on clogging-up (DN >125 standard)

Test: • EN ISO 15848-1 / TA - Luft TÜV-Test-No. TA 09 2016 C04

Parts			
Pos.	Sp.p.	Description	Fig. 52./54./55.059
1		Body	GX5CrNiMo19-11-2, 1.4408
2		Cover	X6CrNiMoTi17-12-2, 1.4571
3	x	Screen	X6CrNiMoTi17-12-2, 1.4571
3.1		Supporting basket	DN >125: X6CrNiMoTi17-12-2, 1.4571
4		Stud	A4-70
5		Hexagon nut	A4
6	x	Gasket	Pure graphite (CrNi laminated with graphite)
L Spare parts			

DN	15	20	25	32	40	50	65	80	100	125	150	200	250	300	350	400	500
----	----	----	----	----	----	----	----	----	-----	-----	-----	-----	-----	-----	-----	-----	-----

**Face-to-face dimension FTF series 1 according to DIN EN 558**

Standard-flange dimensions refer to page 7

L	(mm)	130	150	160	180	200	230	290	310	350	400	480	600
---	------	-----	-----	-----	-----	-----	-----	-----	-----	-----	-----	-----	-----

**Dimensions**

H2	(mm)	94	94	102	102	123	126	148	170	202	285	320	417	
H3	(mm)	130	138	150	143	166	172	206	234	282	388	443	585	
l2	(mm)	48	48	57	57	68	70	85	97	112	138	169	230	
Ød2	(mm)	25	25	31	36	46	55,5	69,5	85,5	105,5	131,5	159	210	
Standard screen	Mesh width	(mm)	1	1	1	1	1	1,25	1,25	1,6	1,6	1,6	1,6	
	Kvs-value <sup>1)</sup>	(m³/h)	6,9	10,8	17,8	26,1	36,7	61	98,6	146	234	376	398	652
	Zeta-value	--	1,7	2,2	2	2,5	3	2,7	2,9	3,1	2,9	2,8	5,1	6
Fine screen	Mesh width	(mm)	0,25	0,25	0,25	0,25	0,25	0,25	0,25	0,25	0,25	0,25	0,25	
	Kvs-value <sup>1)</sup>	(m³/h)	6,2	10,1	16,8	24,3	32,9	49,5	80,3	115	189	303	378	590
	Zeta-value	--	2,1	2,5	2,2	2,8	3,8	4,1	4,4	4,9	4,5	4,2	5,6	7,3
Ratio of the free screen surface area to the area of the nominal diametSp.p.			10	8,4	8,3	7,1	6,8	5,2	4,4	3,7	2,8	2,7	2,4	2,3

on request

Zeta-value ... range of tolerance for Kvs-values acc. to VDI/VDE 2173

<sup>1)</sup> Kvs-values based upon clean screen!

**Weights**

52./54./55.059	(kg)	4	5	6	8	10	13	19	24,5	35,0	51	71	144
----------------	------	---	---	---	---	----	----	----	------	------	----	----	-----

Information / restriction of technical rules need to be observed!

 Operating and installation instructions can be downloaded at [www.ari-armaturen.com](http://www.ari-armaturen.com).

A production permission acc. to TRB 801 No. 45 is available.

The engineer, designing a system or a plant, is responsible for the selection of the correct valve.

Resistance and fitness must be verified (contact manufacturer for information, refer to Product overview and Resistance list).

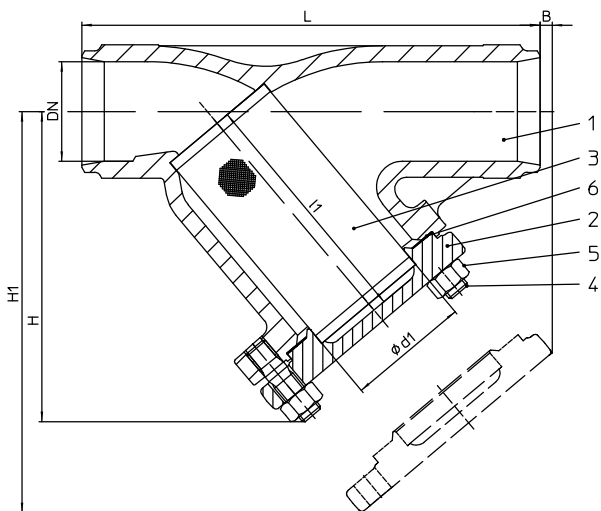
**Strainer - Y-pattern with butt weld ends (Cast steel)**


Figure	Nominal pressure	Material	Nominal diameter
35.080	PN40	1.0619+N	DN15-300

Butt weld ends according to DIN EN 12627 - 4 (refer to page 5)

A supporting basket is necessary, with higher differential pressures, dependent on clogging-up (DN >125 standard)

Test: • EN ISO 15848-1 / TA - Luft TÜV-Test-No. TA 09 2016 C04

Parts			
Pos.	Sp.p.	Description	Fig. 34/35.080
1		Body	GP240GH+N, 1.0619+N
2		Cover	DN ≤100: P250 GH, 1.0460 DN >100: P265 GH, 1.0425
3	x	Screen	X5CrNi18-10, 1.4301
3.1		Supporting basket	DN >125: X5CrNi18-10, 1.4301
4		Stud	25CrMo4, 1.7218
5		Hexagon nut	C35E, 1.1181
6	x	Gasket	Pure graphite (CrNi laminated with graphite)
L Spare parts			

DN	15	20	25	32	40	50	65	80	100	125	150	200	250	300
----	----	----	----	----	----	----	----	----	-----	-----	-----	-----	-----	-----

Face-to-face dimension ETE series 1 according to DIN EN 12982															
L	(mm)	130	150	160	180	200	230	290	310	350	400	480	600	730	850

Dimensions																
H	(mm)	90	100	115	125	150	160	180	215	235	275	305	390	540	680	
H1	(mm)	135	150	180	205	235	250	285	330	365	425	480	610	915	1110	
B	(mm)	10	10	25	35	45	45	25	40	55	65	50	80	230	350	
l1	(mm)	56	68	82	98	114	119	134	149	169	199	224	284	283	317	
Ød1	(mm)	23	28	36	42	50	61,5	78,5	89,5	109,5	137,5	160	210	260	314	
Standard screen	Mesh width	(mm)	1	1	1	1	1	1,25	1,25	1,6	1,6	1,6	1,6	1,6	1,6	
	Kvs-value <sup>1)</sup>	(m³/h)	6,9	10,8	17,8	26,1	36,7	61	98,6	146	234	376	398	652	1225	1873
	Zeta-value	--	1,7	2,2	2	2,5	3	2,7	2,9	3,1	2,9	2,8	5,1	6	4,2	3,7
Fine screen	Mesh width	(mm)	0,25	0,25	0,25	0,25	0,25	0,25	0,25	0,25	0,25	0,25	0,25	0,25	0,25	
	Kvs-value <sup>1)</sup>	(m³/h)	6,2	10,1	16,8	24,3	32,9	49,5	80,3	115	189	303	378	590	1231	1883
	Zeta-value	--	2,1	2,5	2,2	2,8	3,8	4,1	4,4	4,9	4,5	4,2	5,6	7,3	4,1	3,6
Ratio of the free screen surface area to the area of the nominal diametSp.p.			10	8,4	8,3	7,1	6,8	5,2	4,4	3,7	2,8	2,7	2,4	2,3	2,7	2,9
Zeta-value ... range of tolerance for Kvs-values acc. to VDI/VE 2173											<sup>1)</sup> Kvs-values based upon clean screen!					

Weights															
35.080	(kg)	2,5	3	3,5	4	5,5	7,5	12	15	23,5	33	49	106	135	240

Information / restriction of technical rules need to be observed!

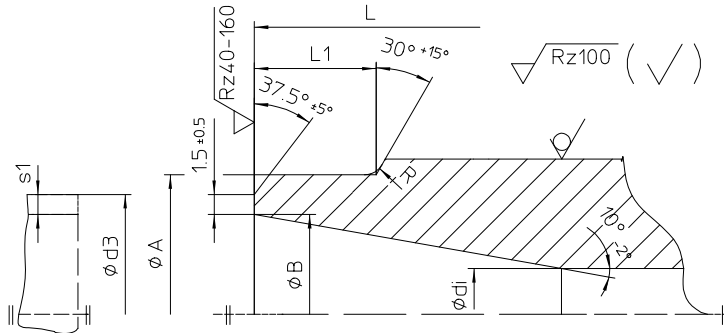
Operating and installation instructions can be downloaded at [www.ari-armaturen.com](http://www.ari-armaturen.com).

A production permission acc. to TRB 801 No. 45 is available.

The engineer, designing a system or a plant, is responsible for the selection of the correct valve.

Resistance and fitness must be verified (contact manufacturer for information, refer to Product overview and Resistance list).

L = Face-to-face dimension  
Edge shaping acc. to DIN EN 25817



DN	15	20	25	32	40	50	65	80	100	125	150	200	250	300	350	400
----	----	----	----	----	----	----	----	----	-----	-----	-----	-----	-----	-----	-----	-----

Butt weld ends according to DIN EN 12627																	
L	(mm)	130	150	160	180	200	230	290	310	350	400	480	600	730	850	980	1100
ØA	(mm)	22	28	35	44	50	62	77	91	117	144	172	223	278	329	362	413
ØB	(mm)	17,3	22,3	28,5	37,2	43,1	53,9	68,9	80,9	104,3	130,7	157,1	204,9	257	307,9	338	384,4
Ødi	(mm)	15	20	25	32	40	50	65	80	100	125	150	200	250	300	330	375
R	(mm)	3	3	3	3	3	3	3	3	3	3	3	5	5	5	5	5
L1 (similar)	(mm)	10	10	10	10	10	10	10	12	14	18	20	20	25	33	45	45
Ød3	(mm)	21,3	26,9	33,7	42,4	48,3	60,3	76,1	88,9	114,3	139,7	168,3	219,1	273,0	323,9	355,6	406,4
s1	(mm)	2	2,3	2,6	2,6	2,6	3,2	3,6	4	5	4,5	5,6	7,1	8	8	8,8	11

Face-to-face dimension ETE series 1 according to DIN EN 12982

Butt weld ends according to DIN EN 12627 Fig. 4

Weld joint according to DIN EN 29692 code number 1.3.3

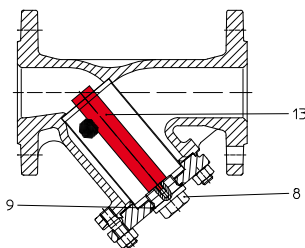
The material used for ARI valves with butt weld ends are:  
GP240GH+N, 1.0619+N acc. to DIN EN 10213-2.

Based on our experience we recommend electric welding process for connecting valves or strainers with tubes or with each other.

Lime based electrodes with an appropriate composite material should be used as filler material for welding.

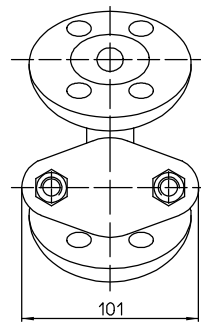
Gas welding should be avoided.

Due to the different material composition and material thickness of valves and tubes, gas welding is more susceptible to produce faults than electric welding (hardness cracks, coarse-grained structure).

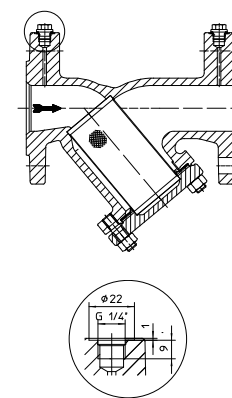


Bar magnet  
Operating temperature: up to +450°C  
DN15 to DN300

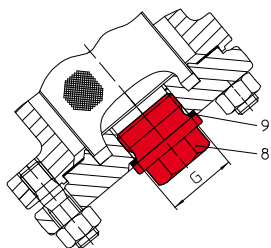
Pos.	Description	Fig. 10./12./22./23./34./35.050; 34./35.080	Fig. 52./54./55.059; 34./35.080
8	Drain screw	C35E, 1.1181	A4
9	Bellows housing	St	Aramid
13	Bar magnet	1.4571 / AINiCo	1.4571 / AINiCo



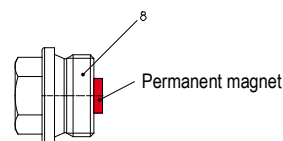
Only DN15:  
view on the cover flange  
(not for stainless steel)



Holes for differential pressure measurement  
on request



DN	G
(mm)	(inch)
15-20	3/8
25-32	3/4
40-80	1
100-150	1 1/2
200-300	2
350-500	on request



Alternative:  
Permanent magnet  
Operating temperature: up to +210°C

Pos.	Description	Fig. 10./12./22./23./34./35.050; 34./35.080	Fig. 52./54./55.059; 34./35.080
8	Drain screw	C35E, 1.1181	A4
9	Bellows housing	St	Aramid

Pos.	Description	Fig. 10./12./22./23./34./35.050; 34./35.080	Fig. 52./54./55.059; 34./35.080
8	Permanent magnet	C35E, 1.1181 / AINiCo	A4 / AINiCo

DN			15	20	25	32	40	50	65	80	100	125	150	200	250	300
<b>Standard-flange dimensions</b>																
Flanges acc. to DIN EN 1092-1/-2 (Flange holes / -thickness tolerances acc. to DIN 2533/2544/2545)																
PN6	ØD	(mm)	80	90	100	120	130	140	160	190	210	240	265	320	--	--
	ØK	(mm)	55	65	75	90	100	110	130	150	170	200	225	280	--	--
	n x Ød	(mm)	4x11	4x11	4x11	4x14	4x14	4x14	4x14	4x18	4x18	8x18	8x18	8x18	--	--
PN16	ØD	(mm)	95	105	115	140	150	165	185	200	220	250	285	340	405	460
	ØK	(mm)	65	75	85	100	110	125	145	160	180	210	240	295	355	410
	n x Ød	(mm)	4x14	4x14	4x14	4x18	4x18	4x18	4x18 <sup>1)</sup>	8x18	8x18	8x18	8x22	12x22	12x26	12x26
PN25	ØD	(mm)	95	105	115	140	150	165	185	200	235	270	300	360	425	485
	ØK	(mm)	65	75	85	100	110	125	145	160	190	220	250	310	370	430
	n x Ød	(mm)	4x14	4x14	4x14	4x18	4x18	4x18	8x18	8x18	8x22	8x26	8x26	12x26	12x30	16x30
PN40	ØD	(mm)	95	105	115	140	150	165	185	200	235	270	300	375	450	515
	ØK	(mm)	65	75	85	100	110	125	145	160	190	220	250	320	385	450
	n x Ød	(mm)	4x14	4x14	4x14	4x18	4x18	4x18	8x18	8x18	8x22	8x26	8x26	12x30	12x33	16x33

<sup>1)</sup> also with 8 bore holes acc. to DIN EN 1092-1/-2 possible.

<b>Pressure-temperature-ratings</b>	Intermediate values for max. permissible operational pressures can be determined by linear interpolation of the given temperature / pressure chart.
-------------------------------------	---

acc. to DIN EN 1092-2			-60°C to <-10°C <sup>1)</sup>	-10°C to 120°C	150°C	200°C	250°C	300°C	350°C	400°C	450°C
EN-JL1040	6	(bar)	--	6	5,4	4,8	4,2	3,6	--	--	--
EN-JL1040	16	(bar)	--	16	14,4	12,8	11,2	9,6	--	--	--
EN-JS1049	16	(bar)	on request	16	15,5	14,7	13,9	12,8	11,2	--	--
EN-JS1049	25	(bar)	on request	25	24,3	23	21,8	20	17,5	--	--

acc. to manufacturers standard			-60°C to <-10°C <sup>1)</sup>	-10°C to 120°C	150°C	200°C	250°C	300°C	350°C	400°C	450°C
1.0619+N	25	(bar)	18,7	25	23,9	22	20	17,2	16	14,8	8,2
1.0619+N	40	(bar)	30	40	38,1	35	32	28	25,7	23,8	13,1
1.0460	25	(bar)	18,7	25	23,9	22	20	17,2	16	14,8	10
1.0460	40	(bar)	30	40	38,1	35	32	28	25,7	23,8	16

acc. to DIN EN 1092-1			-60°C to <-10°C <sup>1)</sup>	-10°C to 100°C	150°C	200°C	250°C	300°C	350°C	400°C	450°C
1.4408	16	(bar)	16	16	14,5	13,4	12,7	11,8	11,4	10,9	--
1.4408	25	(bar)	25	25	22,7	21	19,8	18,5	17,8	17,1	--
1.4408	40	(bar)	40	40	36,3	33,7	31,8	29,7	28,5	27,4	--

<sup>1)</sup> Studs and nuts made of A4-70 (at temperatures below -10°C)

**Please indicate when ordering:**

- Figure-No.
- Nominal pressure
- Nominal diameter
- Special design / accessories

**Example:**

Figure 35.050; Nominal pressure PN40; Nominal diameter DN100; with drain screw.

