

# 10K Gate Valve

**10SMBOF**  
B.B.O.S.Y.  
FF-flanged

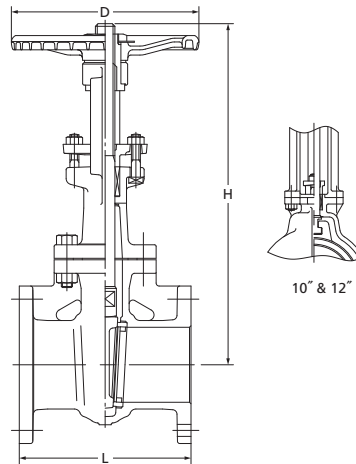

F-F dimension : JIS B 2002  
End flanges : JIS B 2239 10K

120°C Static water..... 1.4MPa  
220°C Steam, air, gas, oil..... 1.2MPa  
300°C Steam, air, gas, oil..... 1.0MPa

- Use for lubricating or hydraulic oil is acceptable. Contact KITZ Corporation for technical advice, if valves are used as heat transfer media.
- Bolting materials will be changed for servicing high temperature exceeding 225°C. Contact KITZ Corporation for detailed information.

### Materials

Parts	JIS material
Body	FCD-S
Bonnet	FCD-S
Stem	SUS403
Disc	SUS403 / SCS1 (1 1/2" ~ 8") SFVC2A + 13Cr (10") SCPH2 + 13Cr (12")
Body seat ring	SUS403
Gland	FCD-S
Gland packing	Non-asbestos Packing
Handwheel	FCD400
Wheel nut	SS400
Bonnet bolt/nut	Carbon Steel
Gland bolt/nut	Carbon Steel
Yoke sleeve	C6782BE (8" ~ 12" : CAC302)
Yoke	FCD-S
Gasket	Non-asbestos Sheet
Name plate	A1050P

### Dimensions

Size	mm										
	mm	40	50	65	80	100	125	150	200	250	300
	inch	1 1/2	2	2 1/2	3	4	5	6	8	10	12
L		165	178	190	203	229	254	267	292	330	356
H (open)		300	352	410	479	566	667	779	993	1181	1404
D		160	200	200	250	250	300	300	350	400	450

NOTE : For flange dimensions, refer to Page 40. ※RF-flanged ends shall be optionally available.

# JIS 10K Lift Check Valve

**10SF**  
S.C.

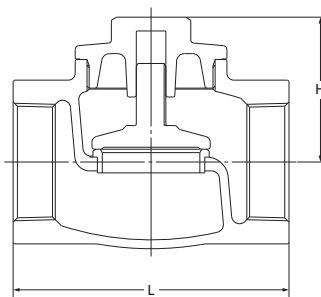

E-E dimension : JIS B 2051  
End threads : JIS B 0203

120°C Static water..... 1.4MPa  
220°C Steam, air, gas, oil..... 1.0MPa

- Use for lubricating or hydraulic oil is acceptable. Contact KITZ Corporation for technical advice, if valves are used as heat transfer media.

### Materials

Parts	JIS material
Body	FCD-S
Cap	SUS403
Disc	SUS403
Body seat ring	SUS403

### Dimensions

Size	mm						
	mm	15	20	25	32	40	50
	inch	1/2	3/4	1	1 1/4	1 1/2	2
L		65	80	90	105	120	140
H		39	42	48	56	65	73