

Forged Steel Check Valve

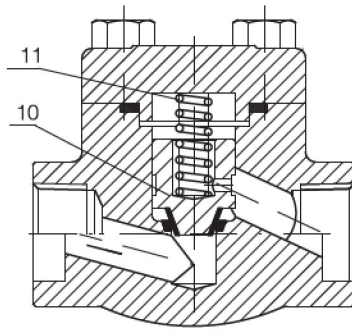

welded bonnet

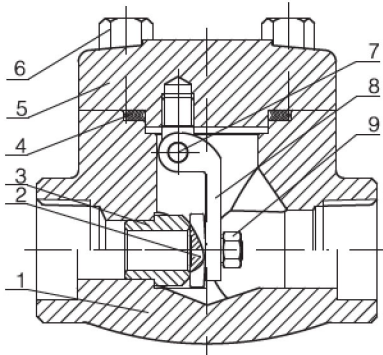

Applicable Standards

1. Design and Manufacture
API 602, BS5352, ASME B16.34
2. Connection end
Socket Weld End(SW):ASME B16.11
Threaded End(NPT):ASME B1.20.1
Butt-Weld End(BW):ASME B16.25
Flange End(RF/RTJ):ASME B16.5
3. Test & Inspection
API 602, API 598
4. Design Description
Bolted Bonnet(BB),
Welded Bonnet(WB),
5. Main Materials:
A105, LF2, F5, F11, F22,
304(L), 316(L), F347, F321,
F51, Alloy 20, Monel

No.	PART	ASTM Material					
		A105	LF2	F11	F304(L)	F316(L)	F51
1	BODY	A105	LF2	F11	F304(L)	F316(L)	F51
2	DISC	F6a	F6a	F6a+STL	F304(L)	F316(L)	F51
3	SEAT	410	410	410+STL	304(L)	316(L)	F51
4	GASKET	304 + Graphite			304+Graphite	316(L)+Graphite	316(L)+Graphite
5	BONNET	A105	LF2	F11	F304(L)	F316(L)	F51
6	BOLT	B7	L7	B16	B8(M)	B8(M)	B8M
7	PIN	410			304(L)	316(L)	F51
8	HINGE	304			304(L)	316(L)	F51
9	NUT	A194 2H			8	8M	8M
10	SPRING	Ss316					

CL150-300-600

Bolt Bonnet/Weld Bonnet. Reduce Port. Outside Screw
RF/RTJ Flange End, Design: API 602

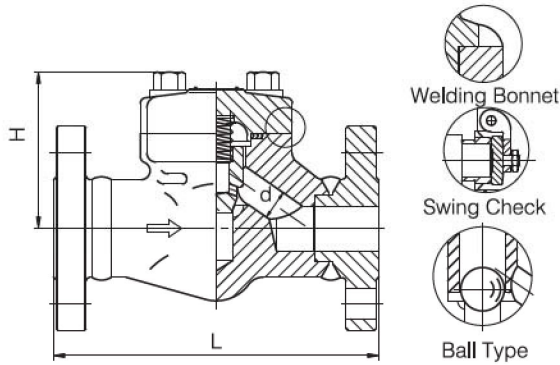

Size (NPS)	R,P	1/2	3/4	1	1.1/4	1.1/2	2	
Face To Face	CL150	L (RF)	108	118	127	140	165	203
	CL300		153	178	203	216	229	267
	CL600		165	191	216	229	241	292
Height	CL150	H	77	81	93	95	103	118
	CL300/600		61	78	84	101	120	133
Flow Port Diameter (d)	Lift type		10.5	13.5	17	22	28	34
	Swing type		10.3	13.5	18	23	29	36
Weight	CL150	Lift type	3.6	4.6	8.5	9.2	12.5	14.8
		Swing type	3.7	4.8	8.8	9.6	13.7	17.8
	CL300	Lift type	4.0	5.8	9.5	10.4	15.6	24.5
		Swing type						
	CL600	Lift type						
		Swing type						

If you want to order the one piece body, please contact sale department

CL900~1500

RF/RTJ Flange End, Design: API 602

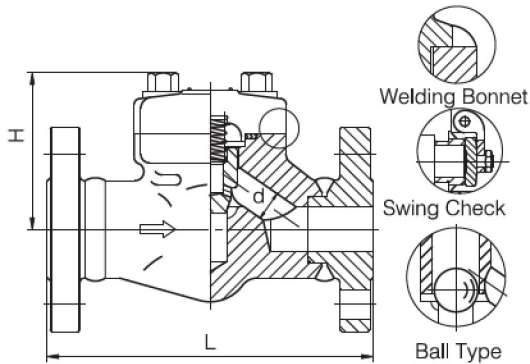

Size (NPS)	R,P	1/2	3/4	1	1.1/4	1.1/2	2	
Face To Face	L	(RF)	216	229	254	279	305	368
		(RTJ)	216	229	254	279	305	371
Height	H	81	93	95	101	118	130	
Flow Port Diameter	d	Lift type	10.5	13.5	17	22	28	34
		Swing type	10.3	13.5	18	23	29	36
Weight(CL1500)		5.2	6.8	10.5	14.5	18	24	

NOTE: If you want to order the one piece body, please contact sale department.

CL900 and CL1500 have the same face to face dimension.

CL800

Bolted bonnet/Welded bonnet. full port/reduce port. outside screw
Threaded, butt-weld, socket weld, Design: API 602

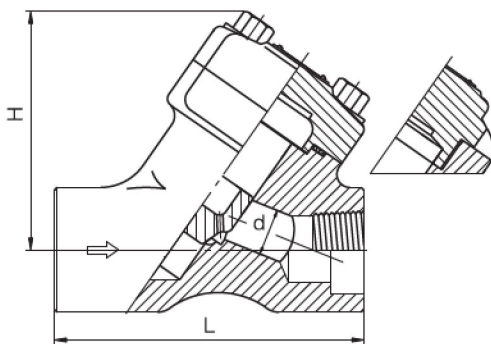

Size (NPS)	R,P	1/2	3/4	1	1.1/4	1.1/2	2	2.1/2
	F,P	3/8	1/2	3/4	1	1.1/4	1.1/2	2
Face To Face	L	98	98	111	140	140	155	170
Height	H	70	70	100	110	120	120	150
Flow Port Diameter	d	10	13	17.5	23	30	35	46
Weight		2.2	2.1	4.2	9	8.9	10	18.6

CL900~1500

Bolted Bonnet/Welded Bonnet, Full Port, Outside Screw and Yoke(OS&Y)
Threaded, Butt-Weld, Socket Weld, Design: API 602

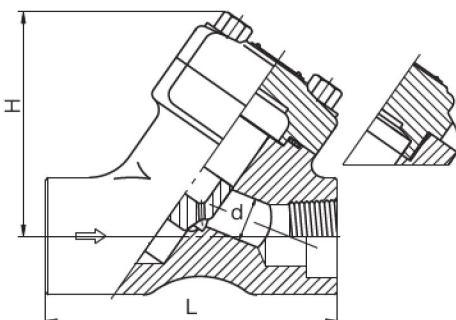

Size (NPS)	F,P	1/2	3/4	1	1.1/4	1.1/2	2
Face To Face	L	111	111	140	140	155	170
Height	H	70	100	110	120	120	150
Flow Port Diameter	d	12	15	20	28	32	40
Weight		4.2	9	8.9	10	18.6	20