

MODEL: SH-29

Globe Valve Screwed Ends...16K

Working pressure marking

- Non-shock water under 120°C: 20 kgf/cm²
- Steam, Air, Oil, Pulse stream under 220°C: 16 kgf/cm²

Hydrostatic test pressure

- Shell: 35 kgf/cm²
- Seat: 25 kgf/cm²
- By air: 6-8 kg

- Material: Ductile Iron
- Size: 3/8" ~ 2 1/2"

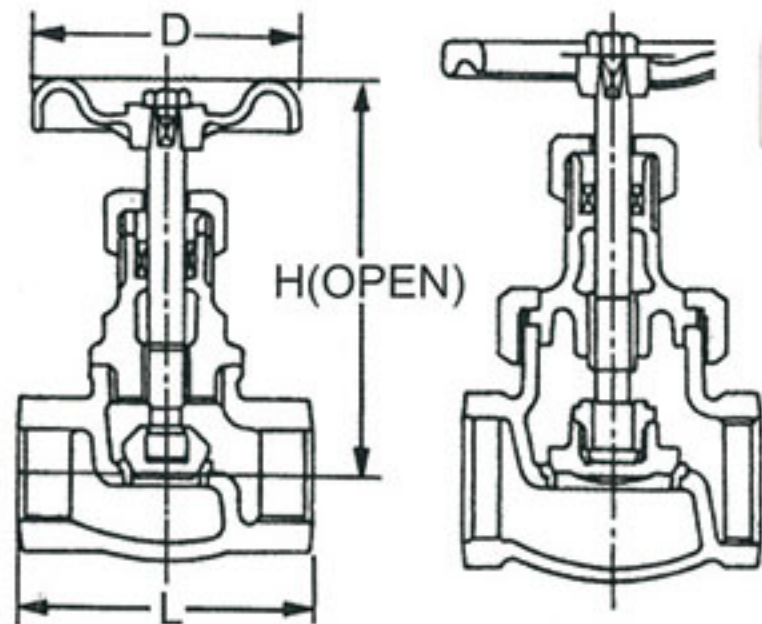

NO	Parts name	Material
1	Body	Ductile Iron(FCD 45)
2	Bonnet	Ductile Iron(FCD 45)
3	Stem	Stainless steel(SUS 410)
4	Disc	Stainless steel(SUS 410)
5	Seat ring	Stainless steel(SUS 410)
6	Packing	Asbestos
7	Handwheel	Cast Iron(FC 20)

MM	INCH	L	H (Open)	H (Open)	D
10	3/8"	65	120	120	65
15	1/2"	65	120	120	65
20	3/4"	80	120	120	80
25	1"	90	135	135	80
32	1 1/4"	105	150	150	100
40	1 1/2"	120	160	160	125
50	2"	140	185	185	140
65	2 1/2"	180	260	260	180