

Through pursuit of functions required for butterfly valves. Variety of product range to comply with user's requirements.

### Specification

Maximum service pressure			
ASME 150	1.03 MPa	10K	1.0 MPa
ASME 200	1.38 MPa	16K	1.6 MPa
ASME 250	1.72 MPa	20K	2.0 MPa
PN16	1.6 MPa		
PM25	2.5 MPa		

Service temperature range	
NBR (Buna-N) seat	0°C to +70°C
EPDM seat	-20°C to +120°C *
Continuous service temperature range	0°C to +100°C

\* There are some fluid type restrictions for the service at 130°C. Contact us for details.

Applicable standards	
Valve design	API 609, MSS-SP 67, EN 593, JIS B 2032
Face to face dimensions	API 609 Category A, MSS-SP 67 W-1: Size 2 to 14
	W-2: Size 16 to 24
	EN 558 basic series 20, ISO 5752 20 Series, JIS B 2002 46 Series

Coupling flanges	
Wafer type	ASME Class 150/200/250
	EN 1092 PN10: DN 50 to DN 350, PN16: All sizes PN25: DN 50 to DN 300
Lugged type	BS 10 Table D/Table E
	JIS 10K/16K/20K
	ASME Class 150/200/250
	EN 1092 PN10: DN 50 to DN 150, PN16: All sizes PN25: DN 50 to DN 300

### Feature

#### Non-peeling Seat-to-body Construction

Molded-in (bonded) seat structure is employed for size 2 to 12. Larger sized valves are provided with replaceable seat. This non-peeling seat-to-body construction assures maintenance-free application for high fluid velocity service\*1, vacuum service\*2 and handling surging fluid velocity. It also guarantees peel-free valve mounting on pipelines.

\*1 Maximum 4 meters/second for on-off service for valves up to size 12, and 3 meters/second for size 14 and larger.

\*2 Up to 30 Torr. Vacuum service is option for size 14 and larger.

#### Spherical Design for Discs and Seats

Rubber seats are spherically designed where they contact top and bottom stems. This protects widely designed rubber seats from peeling or deformation for prolonged service life of valves. Thinly streamlined metal discs are the results of elaborate laboratory study to ultimately minimize the pressure loss.

#### Choice of Materials and Operating Devices

Choice among 4 disc and 2 seat materials and manual, pneumatic or electric valve operating devices makes service applications highly versatile.

#### Integral ISO 5211 Actuator Mounting Flange

Any pneumatic or electric valve actuators provided with ISO 5211 valve mounting flanges can be easily mounted for actuation of valves in the field.

#### Low Valve Operating Torque

Low operating torques are designed low for extension of valve service life and economic consideration in selection of valve operating devices.

#### Light-designed for Operation Efficiency

Designed much lighter than our conventional series for operation efficiency in piping

#### Emission-free Stem Sealing Mechanism

Prevention of external fluid leakage is maximized with a rubber O-ring assembled around the top stem and tight contact between spherically designed rubber seat and spherically designed top and bottom end of the disc.

#### Dew Condensation Prevention

Dew condensation prevention type is optionally available with heat insulating plate (size 2 to 6) or stainless steel stand (size 8 to 24).

### Molded-in (bonded) seat structure

(Size 2 to 12)\*1

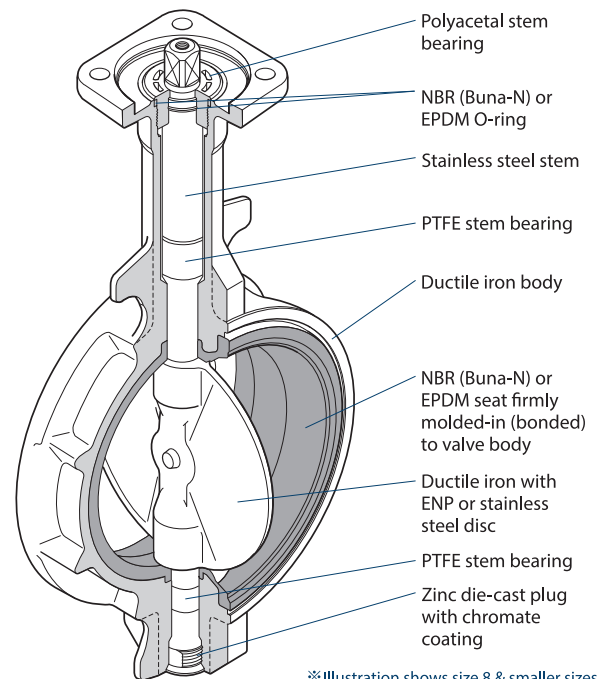

※ Illustration shows size 8 & smaller sizes

### Replaceable seat structure

(Size 14 to 24)\*2

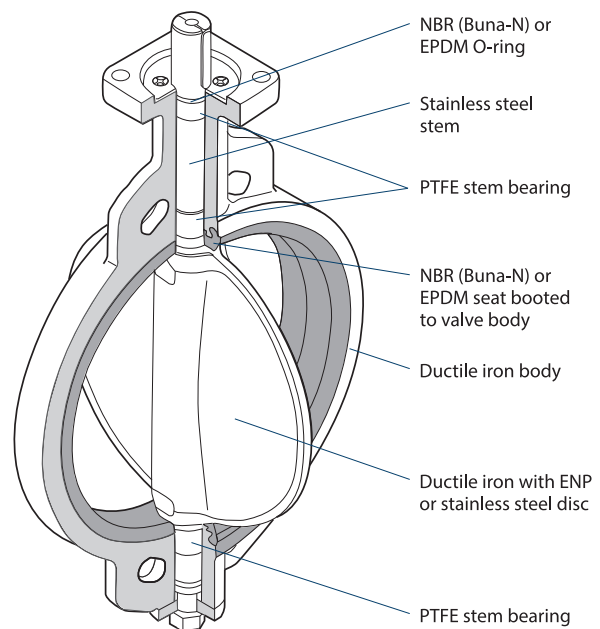

## Flow Coefficient (Cv)

Size		Valve opening			
inch	mm	30°	45°	60°	90°
2	50	10	23	47	124
2½	65	22	50	102	270
3	80	33	74	149	397
4	100	55	125	252	671
5	125	83	189	381	1013
6	150	126	286	576	1532
8	200	230	522	1050	2792
10	250	325	743	1514	4025
12	300	493	1123	2260	6010
14	350	617	1371	2829	7525
16	400	826	1787	3760	10080
18	450	1076	2441	4933	13120
20	500	1311	2969	6012	15990
24	600	1942	4449	8907	23690

## Pressure Loss

(for handling static clean water with valve fully open)

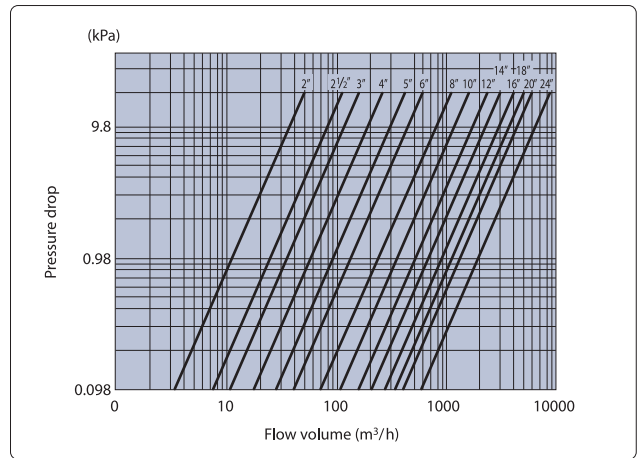

## P-T Rating

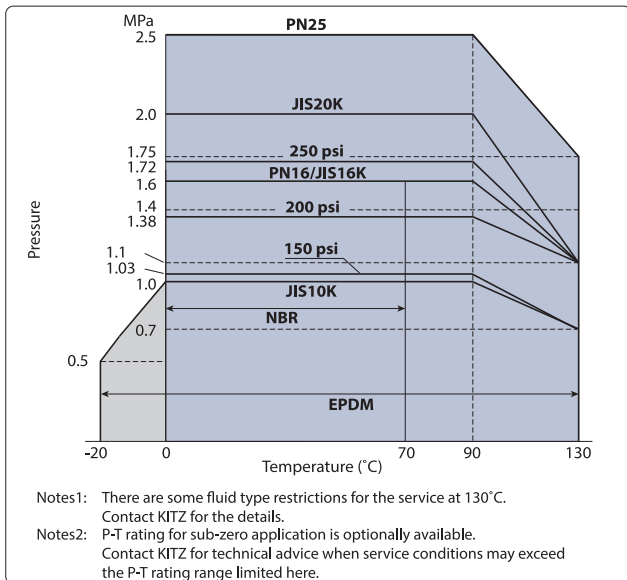

## Flow Characteristics

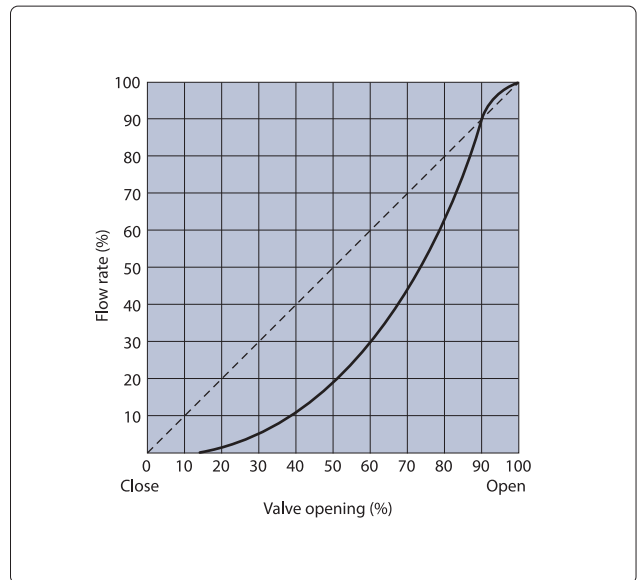

## Standard Materials

Parts	Material	
Body	Ductile Iron	
	Cast Iron (JIS 10K design Size 14" to 24")	
Stem Bottom stem	410 Stainless Steel / 420 Stainless Steel	
Disc	Ductile Iron (Ni-plated) / 304SS / 316SS / Aluminum Bronze (See Explanation of Product Code)	
Seat	NBR (Buna-N) / EPDM	
O-ring	(See Explanation of Product Code)	
Bearing	Polyacetal / Glass Filled PTFE / Metal Backed PTFE	
Plug (Size 2" to 8")	Zinc die-cast (Chromate Coating)	
Operator	Lever	
	Gear	Aluminum Die-cast (Size 2" to 12") Cast-Iron (Size 14" to 24")
	Vertical gear	Cast-Iron

### Wafer Type

### ASME 200/250 psi Design - Lever Operated

200DJ

250DJ

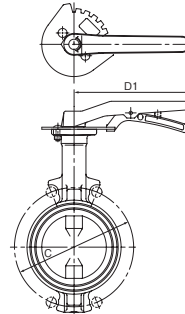
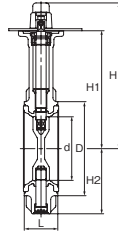

### Dimensions

unit: mm

Size		d	H	H1	H2	L	D	C	D1
mm	inch								
50	2	50	191	147	67	42.9	90	120.5	180
65	2½	65	199	155	75	46	104	139.5	180
80	3	80	217	173	91	46	124	152.5	180
100	4	100	227	183	101	52.3	146	190.5	180
125	5	125	265	211	127	55.6	176	216	230
150	6	150	277	223	139	55.6	206	241.5	230
200	8	197	295	248	169	60.5	257	298.5	350

Disc and seat material coding. Please refer to page 1.

### Wafer Type

### EN PN16/25 Design - Lever Operated

PN16DJ

PN25DJ  E

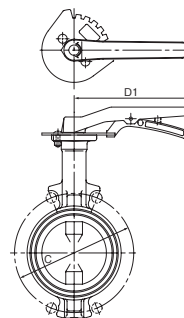
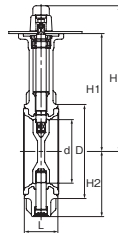

### Dimensions

unit: mm

Size		d	H	H1	H2	L	D	C		D1
mm	inch							PN16	PN25	
50	2	50	191	147	67	43	90	125	125	180
65	2½	65	199	155	75	46	104	145	145	180
80	3	80	217	173	91	46	124	160	160	180
100	4	100	227	183	101	52	146	180	190	180
125	5	125	265	211	127	56	176	210	220	230
150	6	150	277	223	139	56	206	240	250	230
200	8	197	295	248	169	60	257	295	—	350

Disc and seat material coding. Please refer to page 1.

# Ductile Iron Butterfly Valves

**DJ** series

## Wafer Type JIS 10K/16K/20K Design - Lever Operated

- 10DJ    
 16DJ    
 20DJ  E

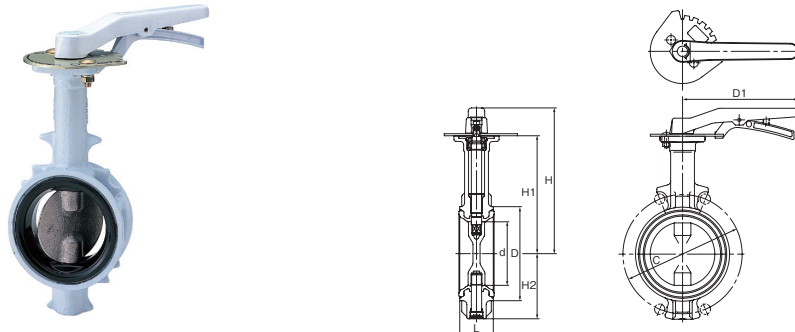

Dimensions unit: mm

Size		d	H	H1	H2	L	D	C		D1
mm	inch							10DJ	16/20DJ	
40	1½	40	172	128	37	33	74	105	—	180
50	2	50	191	147	67	43	90	120	120	180
65	2½	65	199	155	75	46	104	140	140	180
80	3	80	217	173	91	46	124	150	160	180
100	4	100	227	183	101	52	146	175	185	180
125	5	125	265	211	127	56	176	210	225	230
150	6	150	277	223	139	56	206	240	260	230
200	8	197	295	248	169	60	257	290	305	350

Disc and seat material coding. Please refer to page 1.

## Wafer Type ASME 150/200/250 psi Design - Gear Operated

- G-150DJ    
 G-200DJ    
 G-250DJ

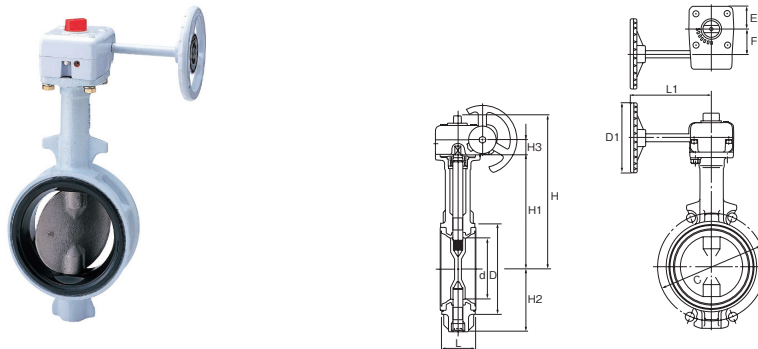

Dimensions unit: mm

Size		d	H	H1	H2	L	D	C	H3	D1 150/200	D1 250	L1 150/200	L1 250	E	F
mm	inch														
50	2	50	194	147	67	42.9	90	120.5	19	80	—	122	—	29	28
65	2½	65	202	155	75	46	104	139.5	19	80	—	122	—	29	28
80	3	80	236	173	91	46	124	152.5	24	110	—	135	—	36	40
100	4	100	246	183	101	52.3	146	190.5	24	110	—	135	—	36	40
125	5	125	274	211	127	55.6	176	216	24	110	—	150	—	36	40
150	6	150	286	223	139	55.6	206	241.5	24	110	—	150	—	36	40
200	8	197	325	248	169	60.5	257	298.5	32	170	—	180	—	51	63
250	10	247	381	304	219	68.3	312	362	32	170	250	180	250	51	63
300	12	296	406	329	244	77.7	364	432	32	170	250	180	250	51	63
350	14	333	445	360	309	78	407	476.5	47	310	—	220	—	54	66
400	16	385	500	415	348	102	466	539.5	47	310	—	220	—	54	66
450	18	434	524	439	372	114	522	578	47	310	—	220	—	54	66
500	20	482	589	488	423	127	575	635	60	500	—	360	—	68	89
600	24	579	637	536	472	154	680	749.5	60	500	—	360	—	68	89

Disc and seat material coding. Please refer to page 1.

### Wafer Type

### EN 16/25 JIS 10K/16K/20K Design - Gear Operated

- G-PN16DJ
- G-PN25DJ  E
- G-10DJ
- G-16DJ
- G-20DJ

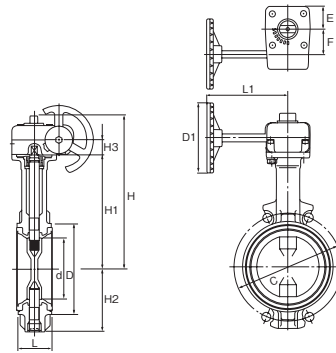

■ Dimensions (PN16/PN25)

unit: mm

Size		d	H	H1	H2	H3	L	D	C		D1		L1		E	F
mm	inch								PN16	PN25	PN16	PN25	PN16	PN25		
50	2	50	194	147	67	19	43	90	125	125	80	80	122	122	29	28
65	2½	65	202	155	75	19	46	104	145	145	80	80	122	122	29	28
80	3	80	236	173	91	24	46	124	160	160	110	110	135	135	36	40
100	4	100	246	183	101	24	52	146	180	190	110	110	135	135	36	40
125	5	125	274	211	127	24	56	176	210	220	110	110	150	150	36	40
150	6	150	286	223	139	24	56	206	240	250	110	110	150	150	36	40
200	8	197	325	248	169	32	60	257	295	310	170	250	180	250	51	63
250	10	247	381	304	219	32	68	312	355	370	250	250	250	250	51	63
300	12	296	406	329	244	32	78	364	410	430	250	250	250	250	51	63
350	14	333	461	360	309	60	78	407	470	—	360	—	350	—	68	89
400	16	385	516	415	348	60	102	466	525	—	360	—	350	—	68	89
450	18	434	540	439	372	60	114	522	585	—	360	—	350	—	68	89
500	20	482	623	488	423	65	127	575	650	—	500	—	400	—	90	134
600	24	579	671	536	472	65	154	680	770	—	500	—	400	—	90	134

■ Dimensions (10DJ)

unit: mm

Size		d	H	H1	H2	H3	L	D	C	D1	L1	E	F
mm	inch												
40	1½	40	175	128	37	19	33	74	105	80	122	29	28
50	2	50	194	147	67	19	43	90	120	80	122	29	28
65	2½	65	202	155	75	19	46	104	140	80	122	29	28
80	3	80	236	173	91	24	46	124	150	110	135	36	40
100	4	100	246	183	101	24	52	146	175	110	135	36	40
125	5	125	274	211	127	24	56	176	210	110	150	36	40
150	6	150	286	223	139	24	56	206	240	110	150	36	40
200	8	197	325	248	169	32	60	257	290	170	180	51	63
250	10	247	381	304	219	32	68	312	355	250	250	60	63
300	12	296	406	329	244	32	78	364	400	250	250	60	63
350	14	333	445	360	309	47	78	407	445	310	220	54	66
400	16	385	500	415	341	47	102	466	510	310	220	54	66
450	18	434	524	439	365	47	114	522	565	310	220	54	66
500	20	482	589	488	414	60	127	575	620	360	350	68	89
550	22	535	612	511	433	60	154	629	680	360	350	68	89
600	24	579	637	536	463	60	154	680	730	360	350	68	89

■ Dimensions (16DJ/20DJ)

unit: mm

Size		d	H		H1	H2		H3		L	D		C	D1		L1		E		F	
mm	inch		16K	20K		16K	20K	16K	20K		16K	20K		16K	20K	16K	20K	16K	20K	16K	20K
50	2	50	194	194	147	67	67	19	19	43	90	90	120	80	80	122	122	29	29	28	28
65	2½	65	202	202	155	75	75	19	19	46	104	104	140	80	80	122	122	29	29	28	28
80	3	80	236	236	173	91	91	24	24	46	124	124	160	110	110	135	135	36	36	40	40
100	4	100	246	246	183	101	101	24	24	52	146	146	185	110	110	135	135	36	36	40	40
125	5	125	274	274	211	127	127	24	24	56	176	176	225	110	110	150	150	36	36	40	40
150	6	150	286	286	223	139	139	24	24	56	206	206	260	110	110	150	150	36	36	40	40
200	8	197	325	325	248	169	169	32	32	60	257	257	305	170	170	180	180	51	51	63	63
250	10	247	381	381	304	219	219	32	32	68	312	312	380	250	250	250	250	60	60	63	63
300	12	296	406	406	329	244	244	32	32	78	364	364	430	250	250	250	250	60	60	63	63
350	14	333	461	445	360	309	285	60	47	78	407	407	480	360	310	350	220	68	54	89	66
400	16	385	516	500	415	348	317	60	47	102	466	466	540	360	310	350	220	68	54	89	66
450	18	434	540	540	439	372	341	60	60	114	522	519	605	360	360	350	350	68	68	89	89
500	20	482	623	589	488	423	408	65	60	127	575	575	660	500	500	400	350	90	68	134	89
550	22	535	646	646	511	433	433	65	65	154	629	629	720	500	500	400	400	90	90	134	134
600	24	579	671	671	536	472	458	65	65	154	680	678	770	500	500	400	400	90	90	134	134

□ Disc and seat material coding. Please refer to page 1.

# Ductile Iron Butterfly Valves

DJ series

## Wafer Type JIS 10K/16K - Vertical Gear Operated

VG-10DJ

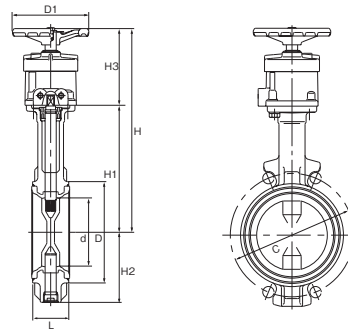

### Dimensions

unit: mm

Size		d	H	H1	H2	H3	L	D	C	D1
mm	inch									
40	1½	40	251	128	37	123	33	74	105	110
50	2	50	270	147	67	123	43	90	120	110
65	2½	65	278	155	75	123	46	104	140	110
80	3	80	285	173	91	112	46	124	150	110
100	4	100	295	183	101	112	52	146	175	110
125	5	125	325	211	127	114	56	176	210	170
150	6	150	337	223	139	114	56	206	240	170
200	8	197	404	248	169	156	60	257	290	200
250	10	247	461	304	219	157	68	312	355	310
300	12	296	486	329	244	157	78	364	400	310
350	14	333	569	360	309	209	78	407	445	360
400	16	385	624	415	341	209	102	466	510	360
450	18	434	648	439	365	209	114	522	565	360
500	20	482	741	488	414	253	127	575	620	500
600	24	579	789	536	463	253	154	680	730	500

Disc and seat material coding. Please refer to page 1.

## Lugged Type ASME 150/200/250 psi Design - Lever Operated

150DJL

200DJL

250DJL

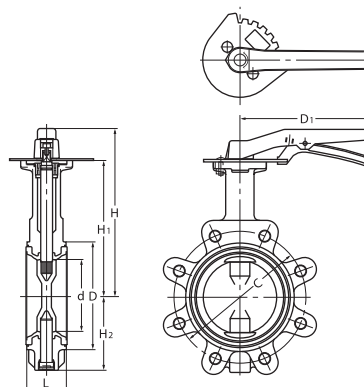

### Dimensions

unit: mm

Size		d	H	H1	H2	L	D	C	D1
mm	inch								
50	2	50	191	147	67	42.9	90	120.5	180
65	2½	65	199	155	75	46	104	139.5	180
80	3	80	217	173	91	46	124	152.5	180
100	4	100	227	183	101	52.3	146	190.5	180
125	5	125	265	211	127	55.6	176	216	230
150	6	150	277	223	139	55.6	206	241.5	230
200	8	197	295	248	169	60.5	257	298.5	350

Disc and seat material coding. Please refer to page 1.

### Lugged Type EN PN16/PN25 Design - Lever Operated

PN16DJL □ □  
 PN25DJL □ E

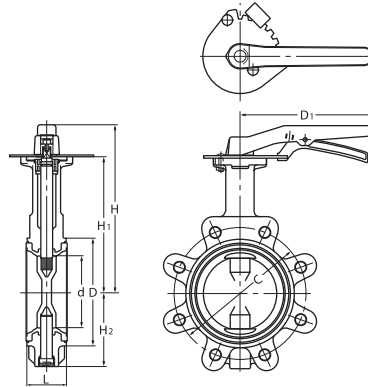

Dimensions unit: mm

Size		d	H	H1	H2	L	D	C		D1
mm	inch							PN16	PN25	
50	2	50	191	147	67	43	90	125	125	180
65	2½	65	199	155	75	46	104	145	145	180
80	3	80	217	173	91	46	124	160	160	180
100	4	100	227	183	101	52	146	180	190	180
125	5	125	265	211	127	56	176	210	220	230
150	6	150	277	223	139	56	206	240	250	230
200	8	197	295	248	169	60	257	295	—	350

□ Disc and seat material coding. Please refer to page 1.

### Lugged Type ASME 150/200/250 psi Design - Gear Operated

G-150DJL □ □  
 G-200DJL □ □\*  
 G-250DJL □ □\*

\* Available up to size 300<sup>A</sup>

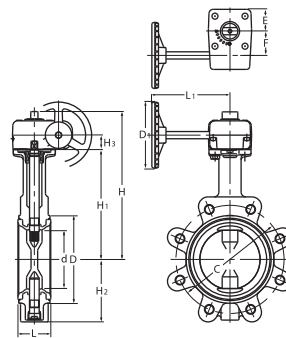
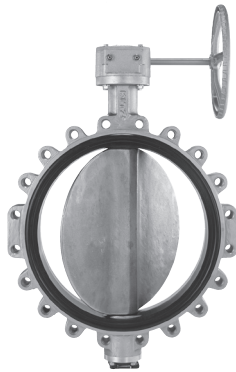

Dimensions unit: mm

Size		d	H	H1	H2	H3	L	D	C	D1 150/200	D1 250	L1		E	F
mm	inch											150/200	250		
50	2	50	194	147	67	19	42.9	90	120.5	80	80	122	122	29	28
65	2½	65	202	155	75	19	46	104	139.5	80	80	122	122	29	28
80	3	80	236	173	91	24	46	124	152.5	110	110	135	135	36	40
100	4	100	246	183	101	24	52.3	146	190.5	110	110	135	135	36	40
125	5	125	274	211	127	24	55.6	176	216	110	110	150	150	36	40
150	6	150	286	223	139	24	55.6	206	241.5	110	110	150	150	36	40
200	8	197	325	248	169	32	60.5	257	298.5	170	170	180	180	51	63
250	10	247	381	304	219	32	68.3	312	362	170	250	180	250	51	63
300	12	296	406	329	244	32	77.7	364	432	170	250	180	250	51	63
350	14	333	445	360	309	47	77.7	407	476.5	310	—	220	—	54	66
400	16	385	500	415	348	47	101.6	466	539.5	310	—	220	—	54	66
450	18	434	524	439	372	47	114.3	522	578	310	—	220	—	54	66
500	20	482	589	488	423	60	127	575	635	500	—	360	—	68	89
600	24	579	637	536	472	60	153.9	680	749.5	500	—	360	—	68	89

□ Disc and seat material coding. Please refer to page 1.



# Ductile Iron Butterfly Valves

DJ series

## Lugged Type

## EN PN16/PN25 Design - Gear Operated

G-PN16DJL

G-PN25DJL

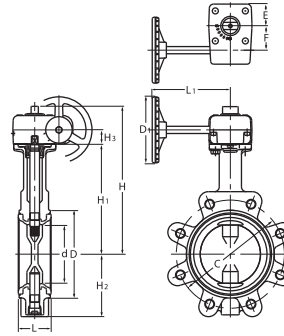
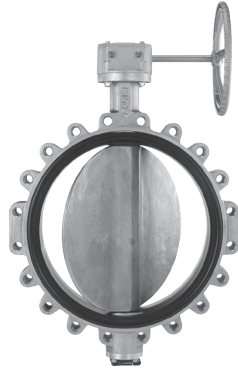

### Dimensions

unit : mm

Size		d	H	H1	H2	H3	L	D	C		D1 PN16	D1 PN25	L1 PN16	L1 PN25	E PN16	E PN25	F
mm	inch								PN16	PN25							
50	2	50	194	147	67	19	43	90	125	125	80	80	122	122	29	29	28
65	2½	65	202	155	75	19	46	104	145	145	80	80	122	122	29	29	28
80	3	80	236	173	91	24	46	124	160	160	110	110	135	135	36	36	40
100	4	100	246	183	101	24	52	146	180	190	110	110	135	135	36	36	40
125	5	125	274	211	127	24	56	176	210	220	110	110	150	150	36	36	40
150	6	150	286	223	139	24	56	206	240	250	110	110	150	150	36	36	40
200	8	197	325	248	169	32	60	257	295	310	170	250	180	250	51	51	63
250	10	247	381	304	219	32	68	312	355	370	250	250	250	250	51	60	63
300	12	296	406	329	244	32	78	364	410	430	250	250	250	250	51	60	63
350	14	333	461	360	309	60	78	407	470	—	360	—	350	—	68	—	89
400	16	385	516	415	348	60	102	466	525	—	360	—	350	—	68	—	89
450	18	434	540	439	372	60	114	522	585	—	360	—	350	—	68	—	89
500	20	482	623	488	423	65	127	575	650	—	500	—	400	—	90	—	134
600	24	579	671	536	472	65	154	680	770	—	500	—	400	—	90	—	134

Disc and seat material coding. Please refer to page 1.